

# MP 260, MP 860

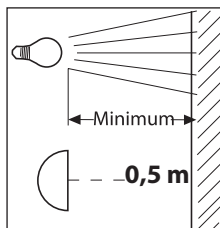

Wegeleuchte/Pathway luminaire/Borne/Luminaria para caminos/  
Lampada per vialetti

## Gebrauchsanleitung/Instruction for use/Notice d'utilisation/ Instrucciones de uso/Istruzioni per l'uso

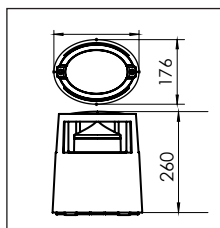
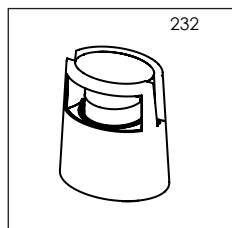

Art.Nr.  
077107 ...  
077108 ...

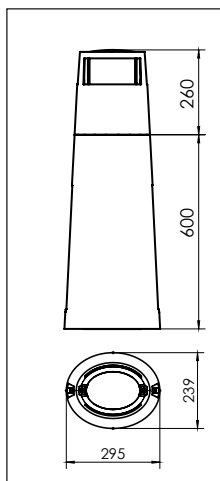
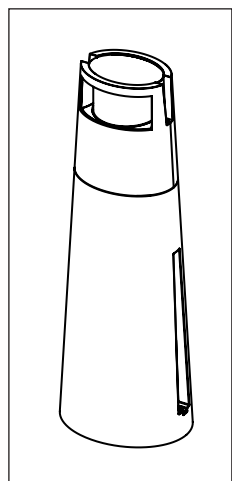

## MP 260, MP 860

Wegeleuchte/Pathway luminaire/Borne/Luminaria para caminos/  
Lampada per vialetti

**Lieferumfang** / scope of supply/ contenu de la livraison/ volumen de suministro/ volume di consegna:

0.77107 ...  
0.77108 ---

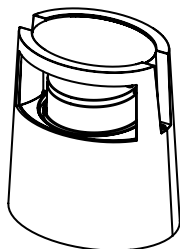

**Service:**

Bei Fragen wenden Sie sich bitte an unsere technische Hotline unter +49 23 55 50 41 26 4 (Montag - Freitag von 08:00 Uhr bis 16:00 Uhr).

**Service:**

If you have any questions, please contact our technical hotline on +49 23 55 50 41 26 4 (Monday - Friday from 8:00 a.m. to 4:00 p.m.).

**Service:**

Si vous avez des questions, veuillez vous adresser à notre hotline technique en téléphonant au +49 23 55 50 41 26 4 (du lundi au vendredi, de 8h à 16h).

**Servicio técnico:**

En caso de consultas, utilice nuestra línea de atención técnica preferente +49 23 55 50 41 26 4 (lunes - viernes desde las 08:00 hasta 16:00 horas)

**Servizio di assistenza:**

Per maggiori informazioni rivolgetevi al nostro servizio tecnico di assistenza digitando il numero +49 23 55 50 41 26 4 (orari di apertura: da lunedì fino a venerdì dalle ore 08.00 fino alle ore 16.00).

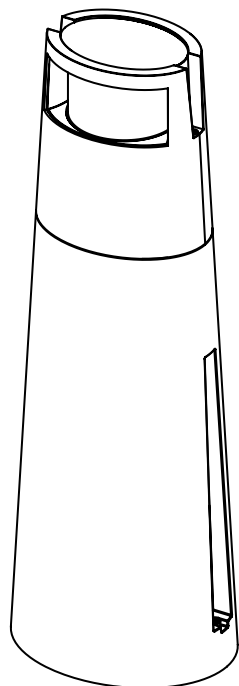

# MP 260

Wegeleuchte/Pathway luminaire/Borne/Luminaria para caminos/  
Lampada per vialetti

## Einbaulage:

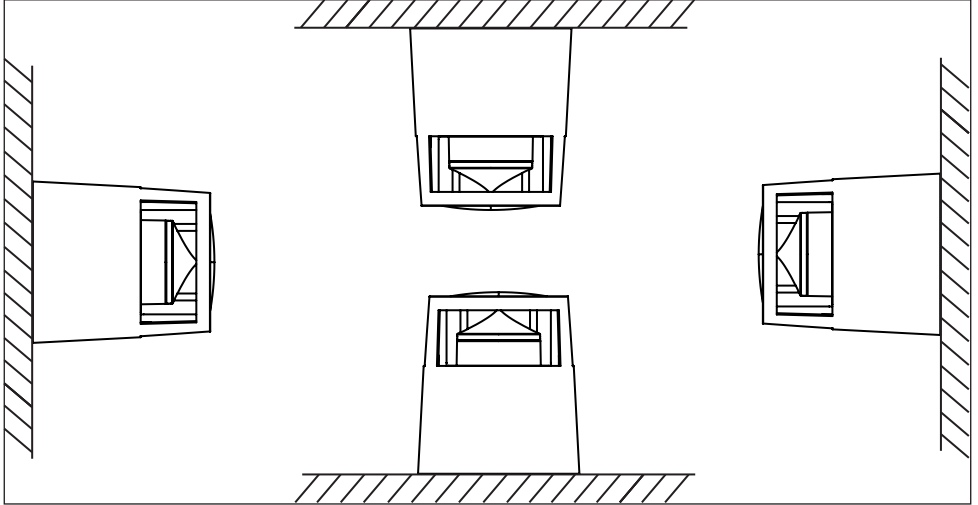

0.77107 ...  
0.77108 ---

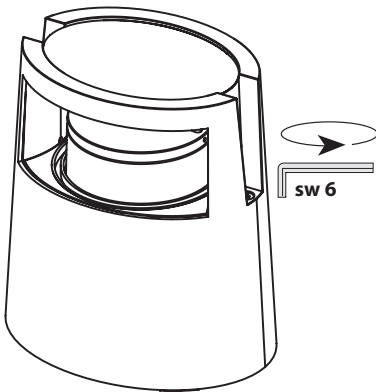

1

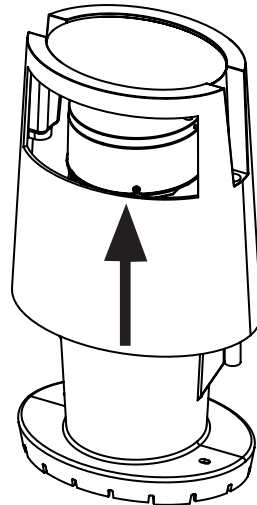

2

# MP 260



Wegeleuchte/Pathway luminaire/Borne/Luminaria para caminos/  
Lampada per vialetti

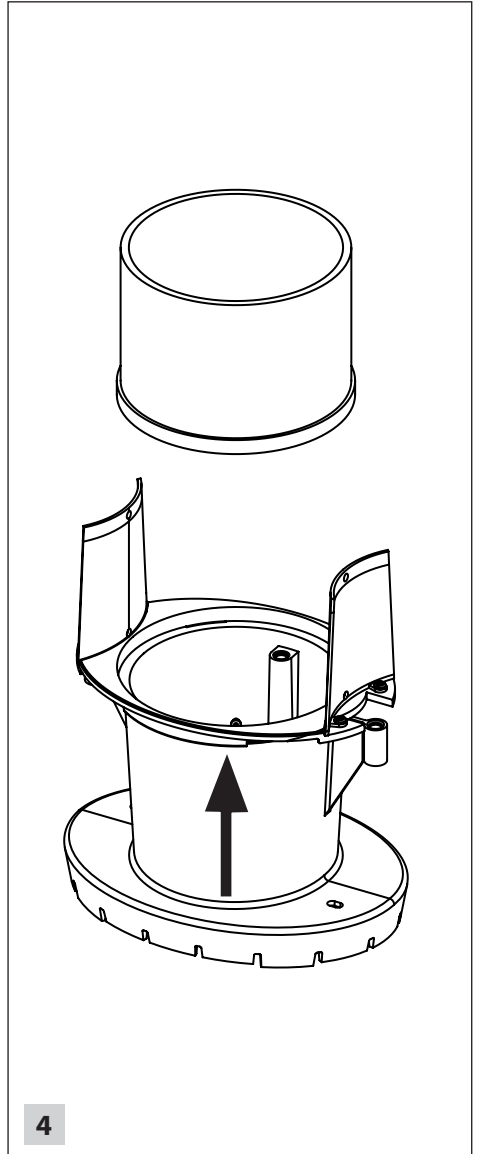
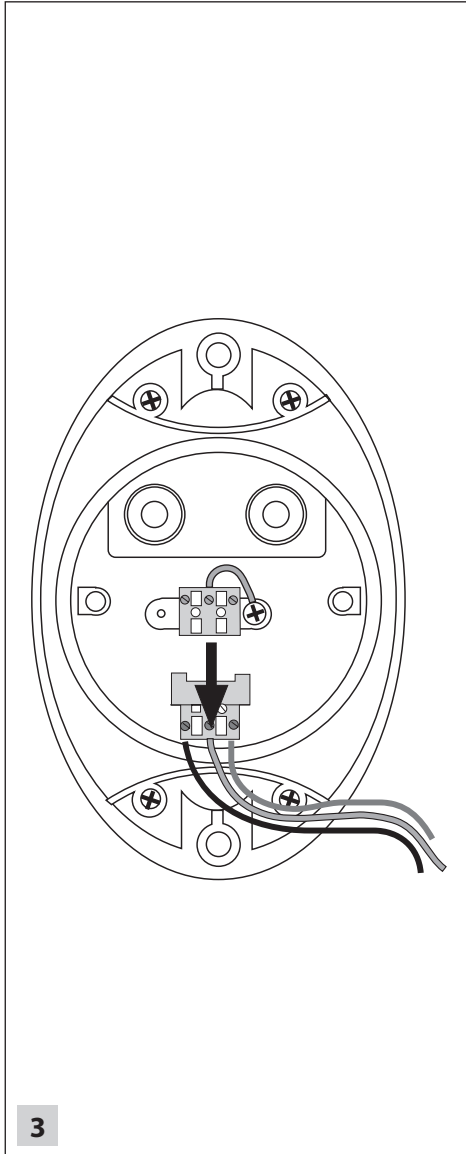

## MP 260

Wegeleuchte/Pathway luminaire/Borne/Luminaria para caminos/  
Lampada per vialetti

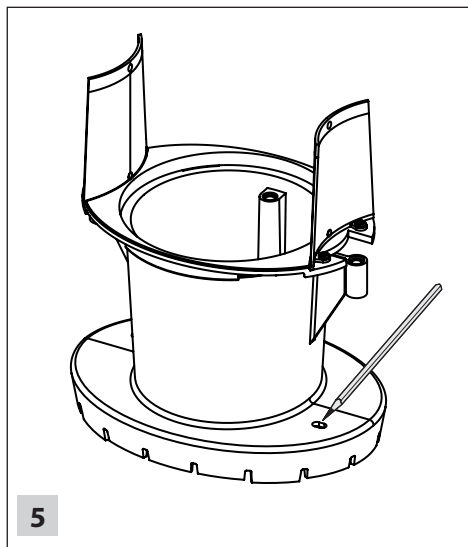

5

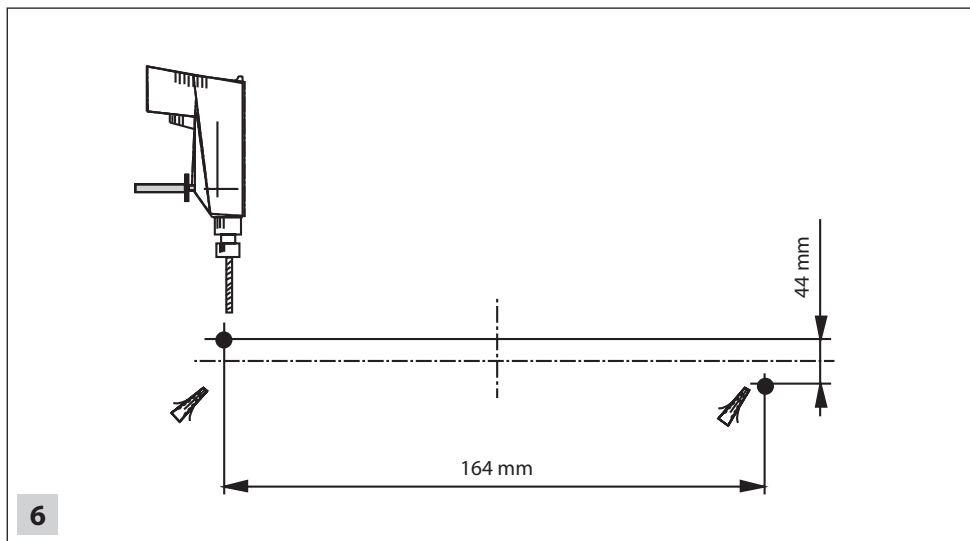

6

# MP 260



Wegeleuchte/Pathway luminaire/Borne/Luminaria para caminos/  
Lampada per vialetti

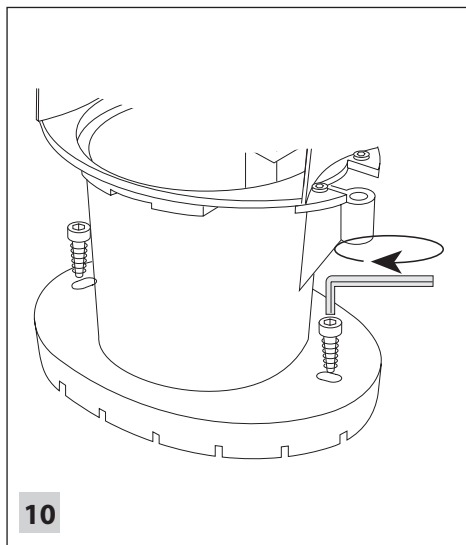
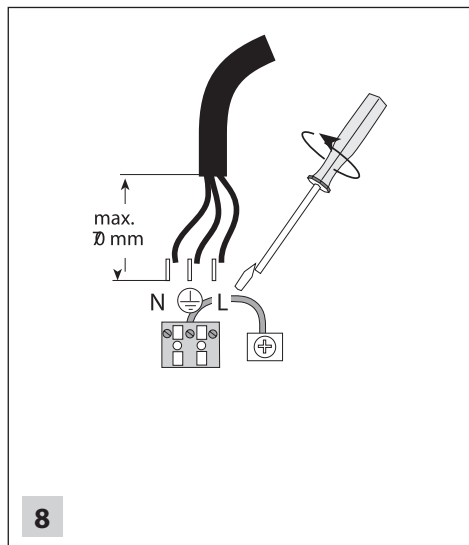
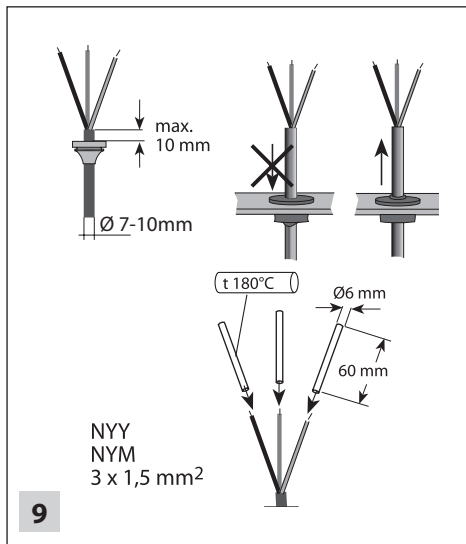
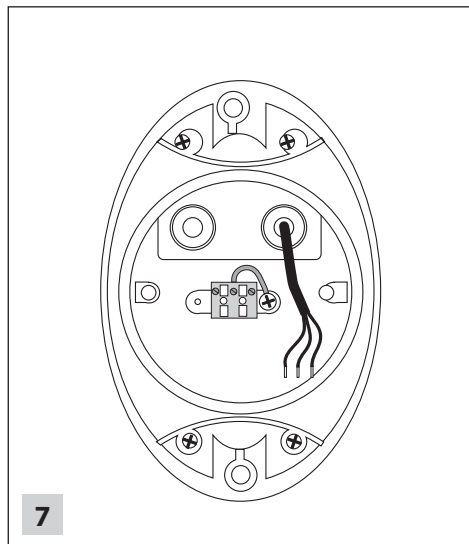

# MP 260

Wegeleuchte/Pathway luminaire/Borne/Luminaria para caminos/  
Lampada per vialetti

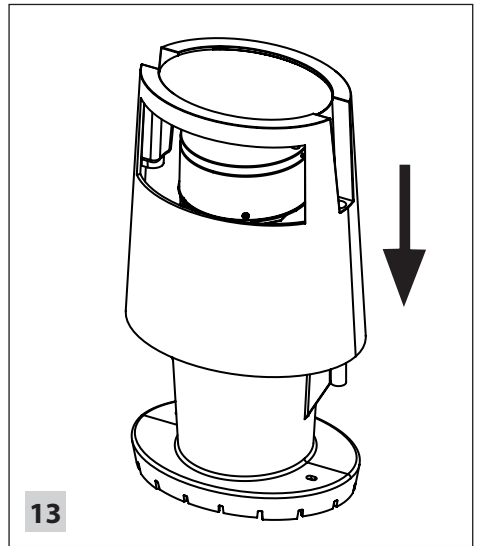
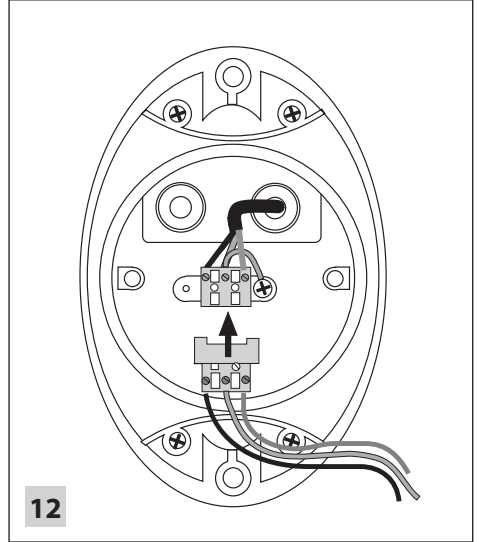
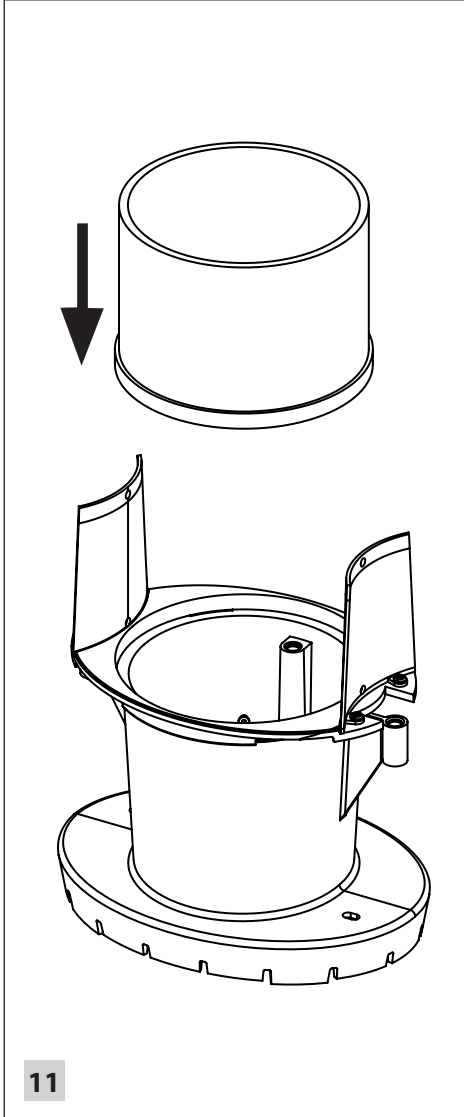

## MP 260

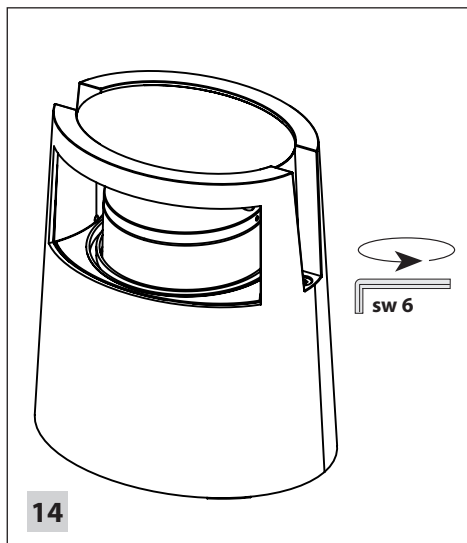

Wegeleuchte/Pathway luminaire/Borne/Luminaria para caminos/  
Lampada per vialetti



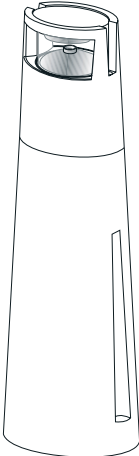

## MP 860

Wegeleuchte/Pathway luminaire/Borne/Luminaria para caminos/  
Lampada per vialetti

			
	0.77107.03-916	100 151	
	0.77107.03-726	100 150	
	0.77107.04-916	100 151	
	0.77107.04-726	100 150	
	0.77108.03-916	100 151	
	0.77108.03-726	100 150	
	0.77108.04-916	100 151	
	0.77108.04-726	100 150	

# MP 860

Wegeleuchte/Pathway luminaire/Borne/Luminaria para caminos/  
Lampada per vialetti

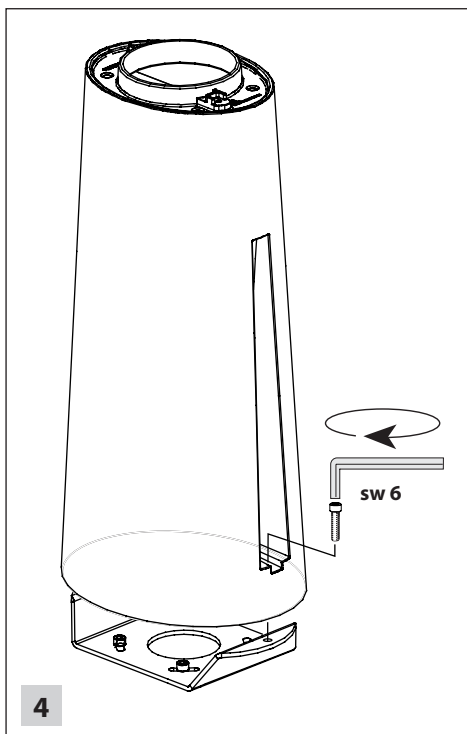
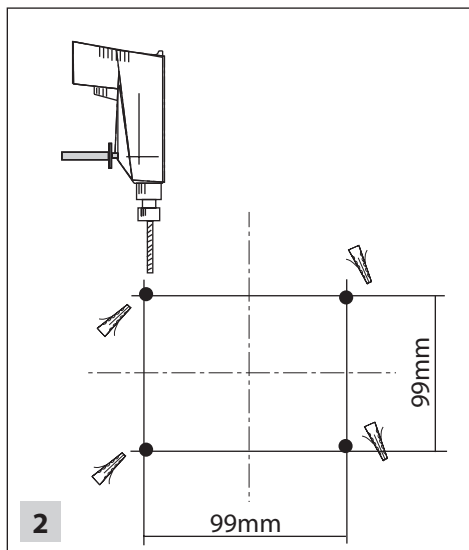
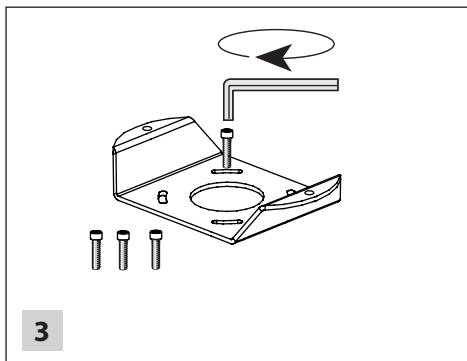
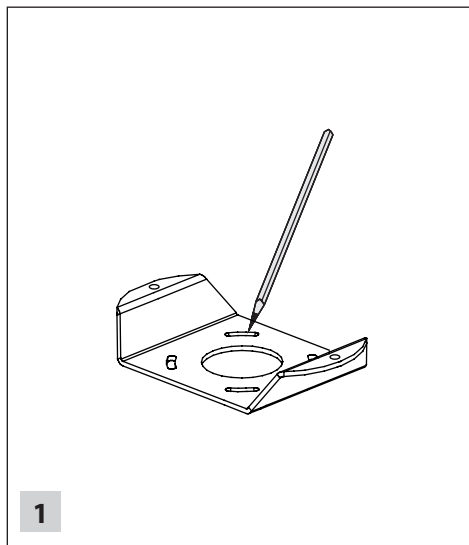

# MP 860

Wegeleuchte/Pathway luminaire/Borne/Luminaria para caminos/  
Lampada per vialetti

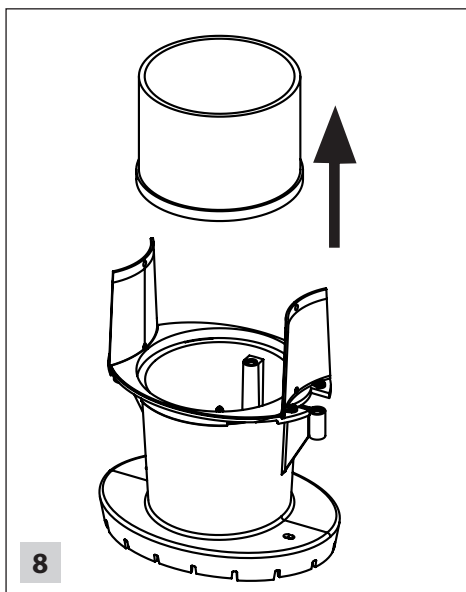
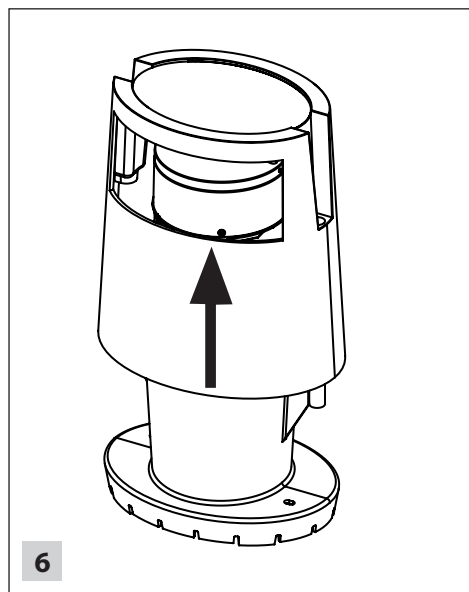
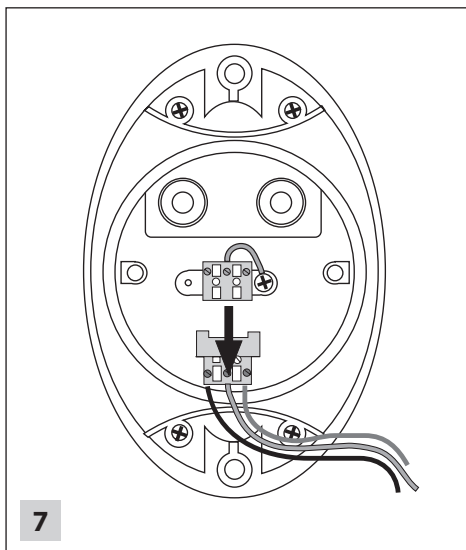
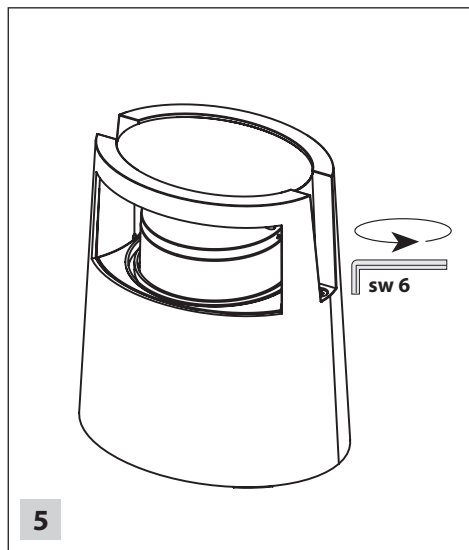

# MP 860



Wegeleuchte/Pathway luminaire/Borne/Luminaria para caminos/  
Lampada per vialetti

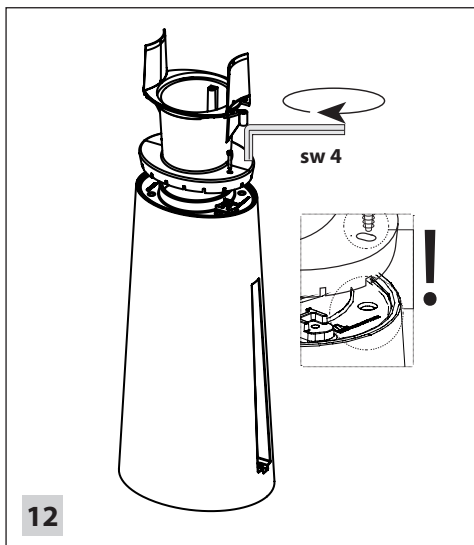
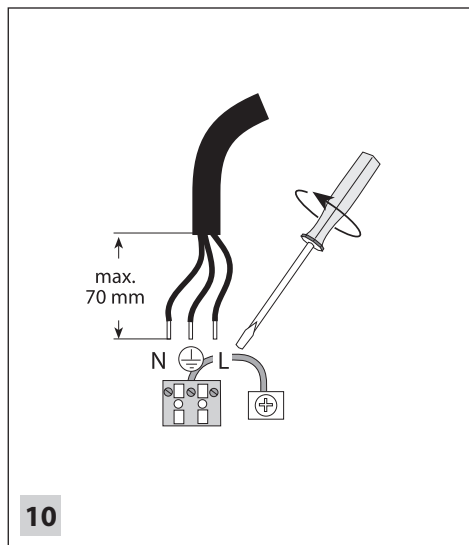
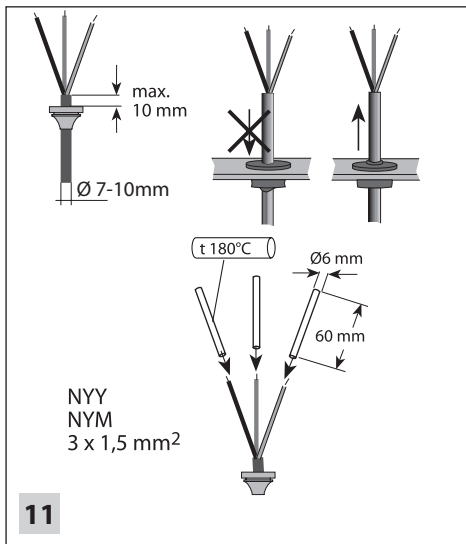
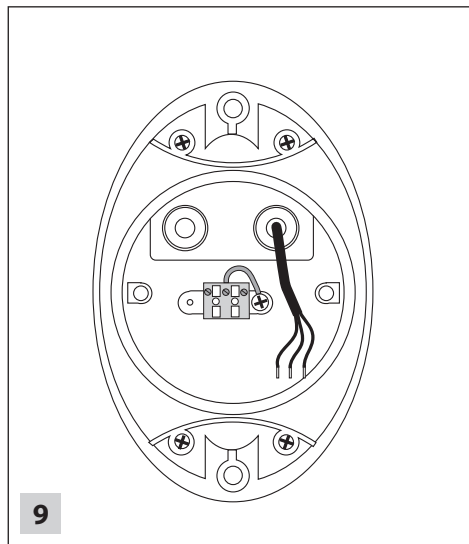

# MP 860

Wegeleuchte/Pathway luminaire/Borne/Luminaria para caminos/  
Lampada per vialetti

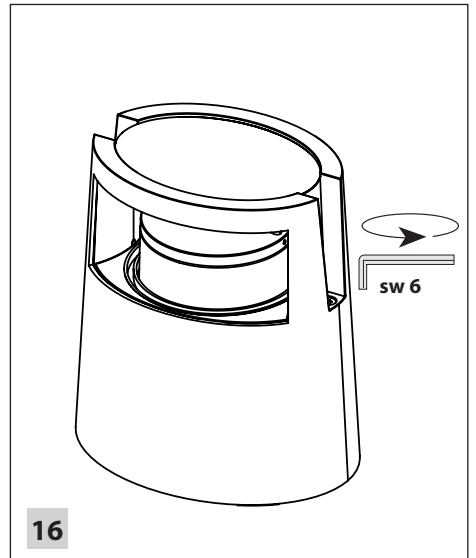
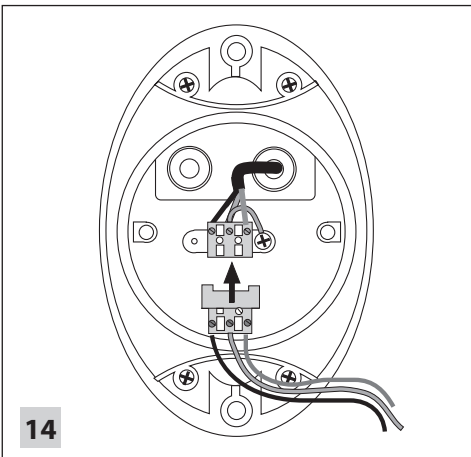
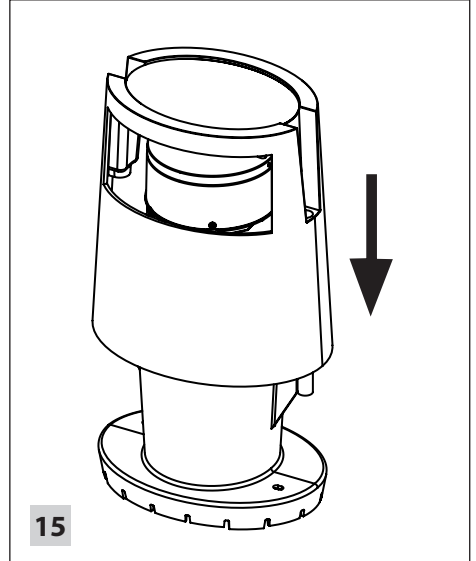
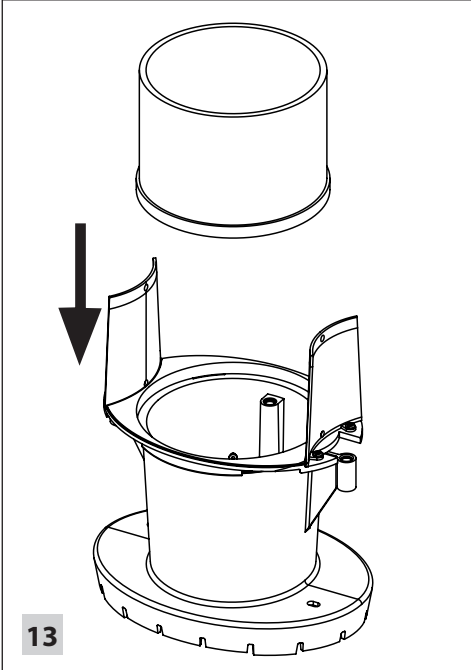

# MP 860



Wegeleuchte/Pathway luminaire/Borne/Luminaria para caminos/  
Lampada per vialetti

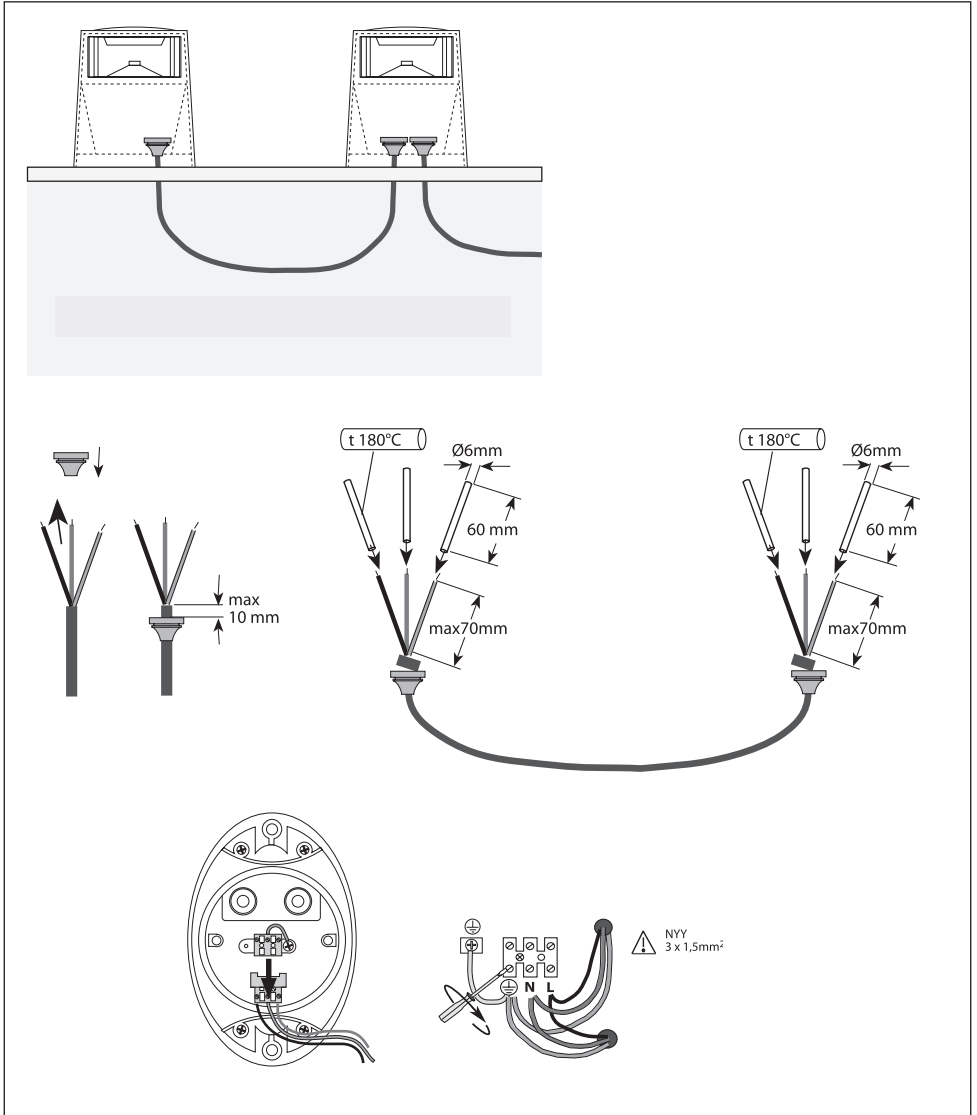



# HOFFMEISTER

Hoffmeister Leuchten GmbH

Gewerbering 28-32  
58579 Schalksmühle  
Germany  
Telefon +49 (0) 23 55-50 41-0  
Telefax +49 (0) 23 55-50 41-328  
www.hoffmeister.de  
mail@hoffmeister.de

Original **HOF FMEISTER**Produkt - deshalb nur Original **HOF FMEISTER**- Teile verwenden.

This is an original **HOF FMEISTER**product - therefore use original **HOF FMEISTER**parts only.

Ceci est un produit d'origine **HOF FMEISTER** pour cette raison, utilisier uniquement des pièces d'origine **HOF FMEISTER**

Eso es un producto original **HOF FMEISTER** por eso utilizar solamente piezas de recambio originales **HOF FMEISTER**

Questo è un prodotto originale **HOF FMEISTER** per questo impiegare esclusivamente ricambi originali **HOF FMEISTER**

**Unsere** Gewährleistung gilt nur bei Beachtung dieser Produktinformation.

Sie erlischt insbesondere bei:

- Nichteinhaltung der Montagehinweise
- Veränderung der Leuchte
- Nichtbeachtung der Einbaumaße

**Our** guarantee is contingent upon the observance of this product information.

In particular it does not apply in cases of:

- noncompliance with mounting instructions
- modification of the luminaire
- nonrespect of recessing dimensions

**Note** garantie dépend de l'observation de cette information sur le produit.

Elle s'éteint notamment dans les cas suivants:

- non-observation des instructions de montage
- modification du luminaire
- non-respect des dimensions d'encastrement

**Nuestra** garantía depende de la observación de esta información sobre el producto.

Prescribe particularmente en los casos siguientes:

- no observación de las instrucciones de montaje
- modificación de la luminaria
- inobservancia de las dimensiones de empotrado

**Nostra** garanzia è dipendente della osservanza di questa informazione di prodotto.

Perde la validità particolarmente nel caso di:

- inosservanza dei istruzioni di montaggio
- modificazione dell'apparecchio di illuminazione
- inosservanza dei dimensioni di incasso

Diesen Kontrollschein bei Reklamationen bitte mit zurückschicken.

In case of complaints please return this control label with the product.

En cas de réclamation veuillez retourner cette fiche de contrôle avec le produit.

En caso de reclamaciones, sírvase devolvérnos este talón de inspección junto con el producto.

Rispedire questa bolletta di controllo insieme con il prodotto in caso di reclamo.

Produktions-Serie  
Production series  
Série de production  
Serie de producción  
Serie di produzione

